

# LAVADORA MOD. LAV-3



## Características principales:

Largo total de la máquina:.....4050 mm  
 Ancho máximo:.....1550 mm  
 Altura máxima:.....2200 mm  
 Potencia total instalada:.....17 cv Aproximadamente  
 Tensión de trabajo:.....400VAC  
 Tensión de servicio:.....24 VDC  
 Velocidad de la banda:.....de 1 a 6 m/min. regulable  
 PESO TOTAL:.....2500 kg.

## Dimensiones:

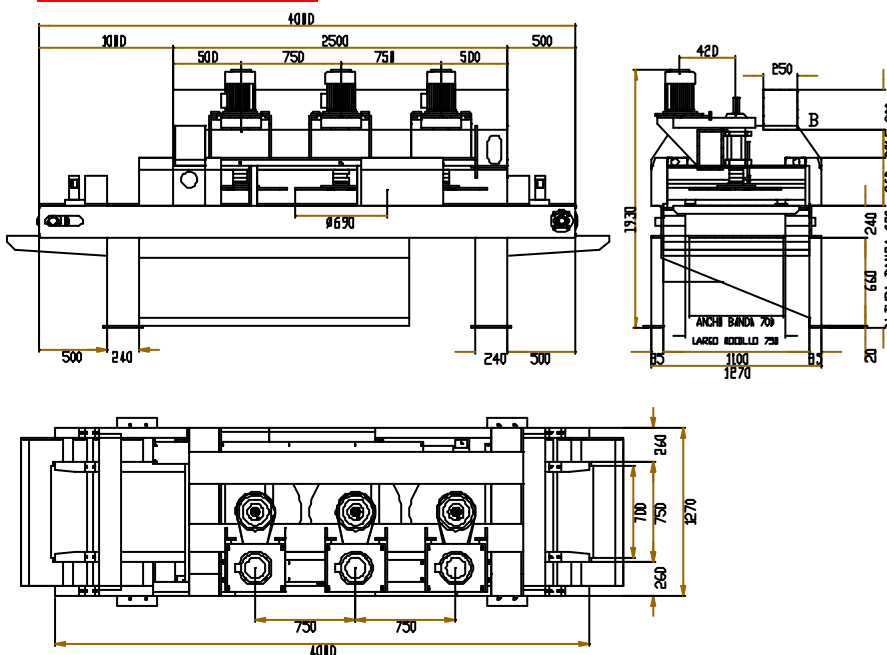

**PRETOMMAQUINARIA, S.L.**  
 CONSTRUCCIÓNDEMAQUINARIA  
 PARATERRAZOYMÁRMOL  
 C/Lugo, s/n-TOMELLOSO-ESPAÑA  
 Tel.: +34926506570-+34926512912  
 Fax: +34926506562  
 http://www.pretom.com  
 e-mail: pretom@pretom.com

