

DOSIFICADOR DE PASTA



Características principales:

Largo total de la máquina:	1959 mm
Ancho máximo:	1155 mm
Altura máxima.:	2564 mm
Potencia total instalada:	10 CV
Tensión de trabajo:	400 VAC
Tensión de servicio:	24 VDC
PESO TOTAL:	1000 Kg

Dimensiones:

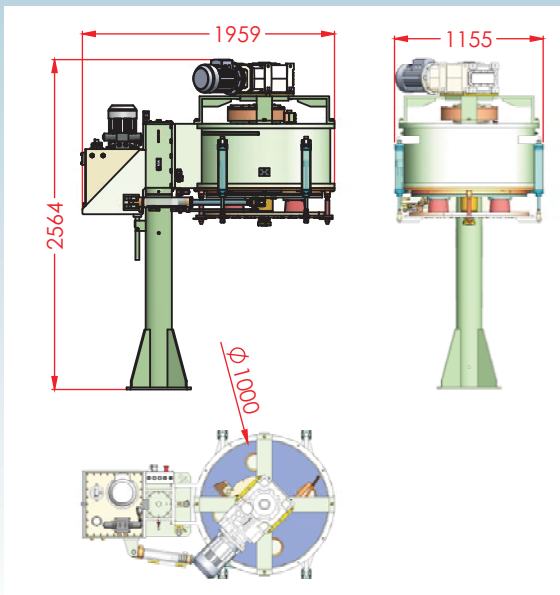

PRENSAS DE TOMELLOSO, S.A.
CONSTRUCCIÓN DE MAQUINARIA
PARA TERRAZO Y MÁRMOL
C/ Lugo, s/n - TOMELLOSO - ESPAÑA
Tel.: +34 926 506 570 - +34 926 512 912
Fax: +34 926 506 562
<http://www.pretom.com>
e-mail: pretom@pretom.com

