

CARRETILLA AUTOMÁTICA MOD. SCA 1500



Características principales:

Longitud total de la máquina:	3830 mm
Ancho máximo:	3050 mm
Altura máxima:	2400 mm
Potencia total instalada:	11'5 CV
Tensión de trabajo:	400 VAC
Tensión de servicio:	24 VDC
PESO TOTAL:	3800 Kg

Dimensiones:

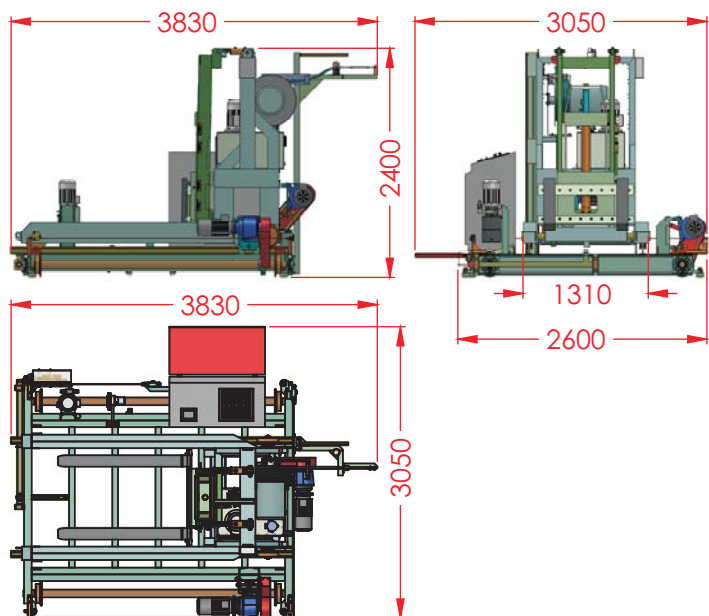

PRENSAS DE TOMELLOSO, S.A.
CONSTRUCCIÓN DE MAQUINARIA
PARA TERRAZO Y MÁRMOL
 C/ Lugo, s/n - TOMELLOSO - ESPAÑA
 Tel.: +34 926 506 570 - +34 926 512 912
 Fax: +34 926 506 562
<http://www.pretom.com>
 e-mail: pretom@pretom.com

